

**The Trump Administration will inherit a Cold War  
Nuclear Doomsday Machine still on hair trigger**

Frank von Hippel, Program on Science and Global Security and  
International Panel on Fissile Materials, Princeton University

Physics Colloquium, University of Michigan, Ann Arbor,  
18 January 2017

**Outline**

- Fundamentals and dangers
- What we have
- The plan to modernize everything
- Less costly, less dangerous alternatives?
- What physicists can do to educate themselves and then their fellow citizens.

## Explosive fission chain reaction

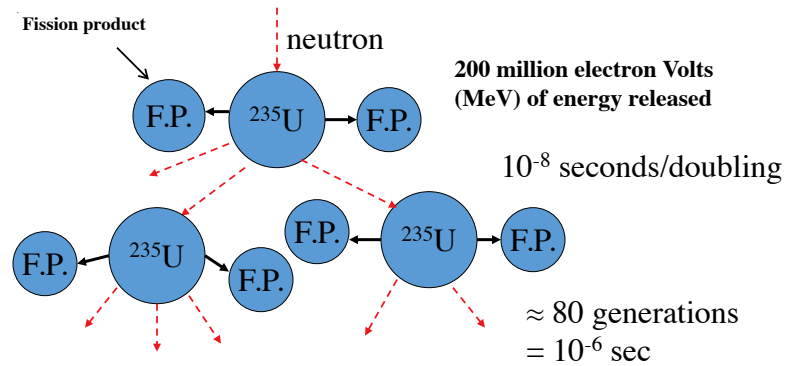

$2^{81} = 2.5 \times 10^{24}$  = number of U atoms in 1 kilogram (kg)

*Fissioning 1 kg  $^{235}\text{U}$  or  $^{239}\text{Pu}$  releases energy equivalent to 16 million kg TNT  
—approximate yield of Hiroshima and Nagasaki bombs.*

Most U.S. nuclear warheads today have 10-30 times that “yield.”



**Hiroshima, August 1945 after the firestorm burned out  
~125,000 deaths from**

- **Direct nuclear radiation** from the nuclear explosion
- **Burns** from the fireball
- **Blast** from the explosive expansion of the fireball
- **Firestorm** from fires merging
- **Radiation-induced cancer**

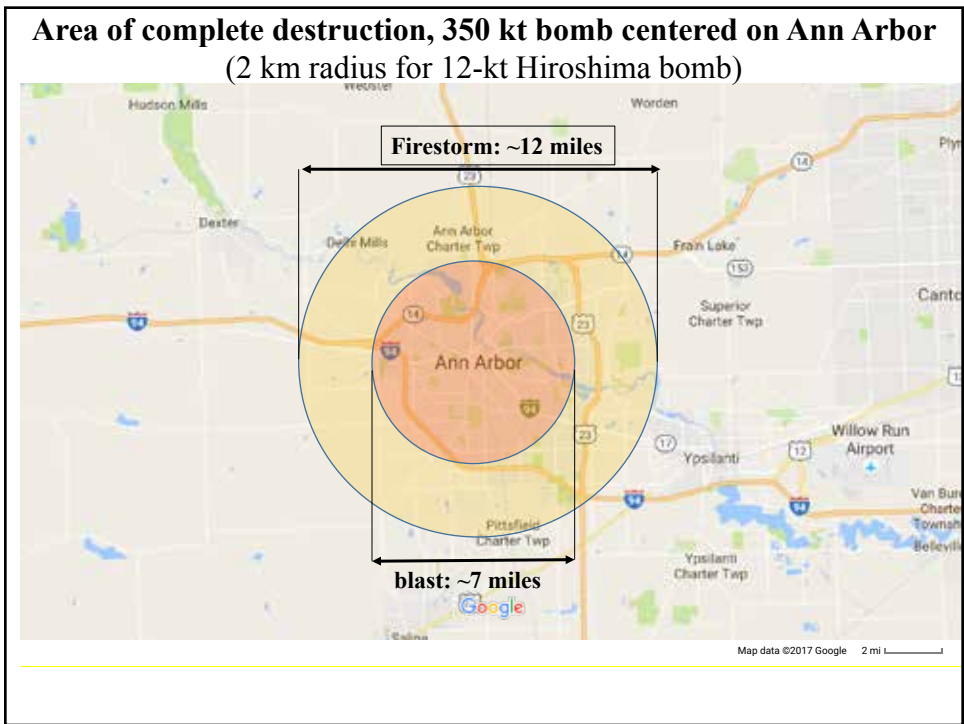
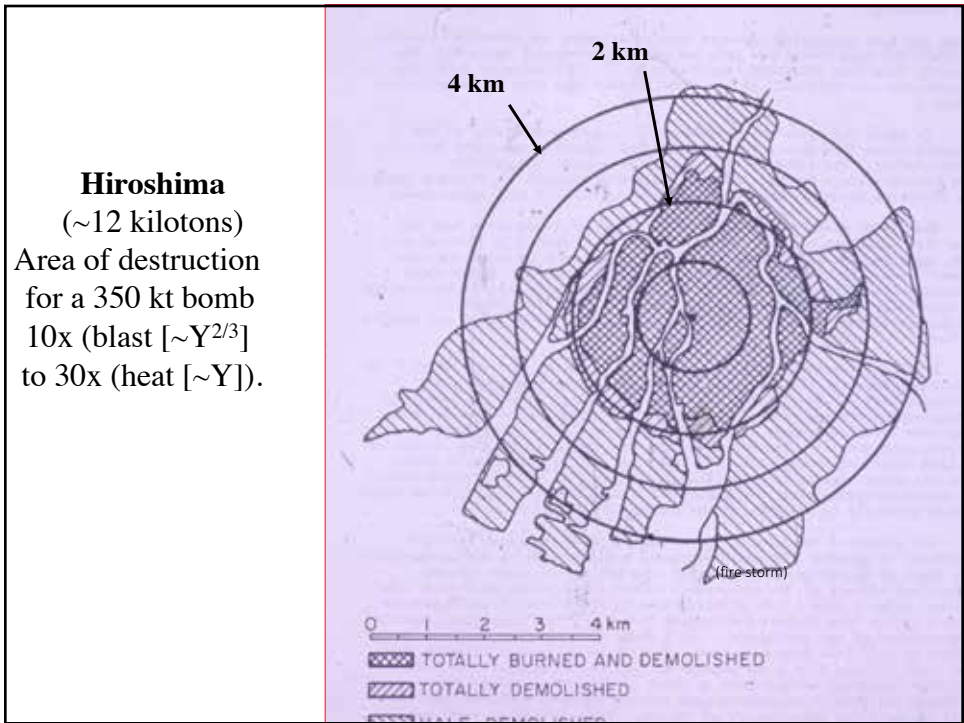

## U.S. nuclear warheads: Fewer but still 10 times the threshold requirement for ending civilization

1962 Cuban missile crisis-  
launched nuclear arms  
control (atmospheric test  
ban in 1963).

Bush-Gorbachev  
reciprocal reductions  
of "tactical" warheads

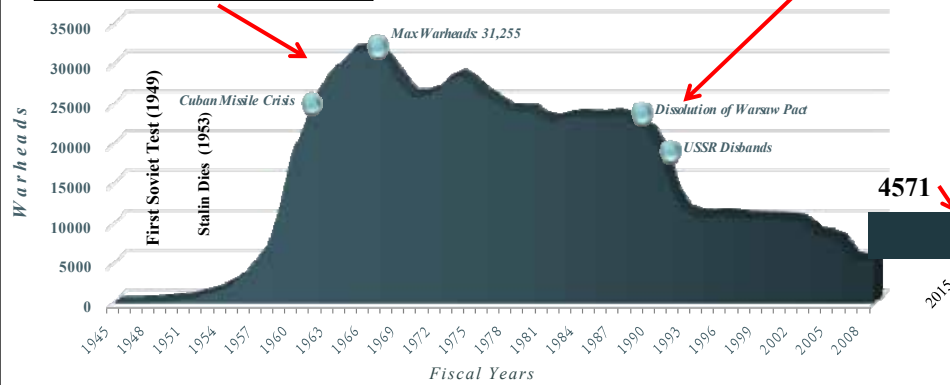

## The public and most of Congress think that the dangers went away with the end of the Cold War

Few members of Congress have any idea about nuclear weapons any more.

<http://youtu.be/2dhllkLpr2Q>

“More than 70 members of Congress were polled and 99% of them did not know -- even roughly speaking -- how many nuclear weapons the United States has. 95% could not think of any situation in which the United States should use nuclear weapons, yet \$60 billion is still spent each year on them.” Global Zero, published on Jun 21, 2013

## U.S. Nuclear Arsenal Currently Has

~ 4700 operational warheads including

~ 2600 reserve +

~ 2100 deployed on:

~ 440 ICBMs (Intercontinental Ballistic Missiles) with one warhead ea.

~1150 on 12 Ballistic Missile Submarines (SSBNs) with 24 missiles ea.

~ 200 nuclear-armed air-launched cruise missiles for B52 bombers

~ 100 nuclear bombs for B-2 bombers

~200 nuclear bombs for fighter-bombers in West Europe and Turkey

Hans M. Kristensen and Robert S. Norris, "United States nuclear forces, 2016," *Bulletin of the Atomic Scientists*, (non-governmental estimates based on New START declarations, U.S. declarations at the 2015 NPT Review Conference and other public information)

We don't know the exact total but Russia has about the same number of warheads for long-range missiles and bombers, more short-range and fewer reserve warheads.

Hans M. Kristensen and Robert S. Norris, "Russian nuclear forces, 2016," *Bulletin of the Atomic Scientists*.

## Deaths from a U.S "counterforce" strike

Tens of million from direct effects (blast, fire, fallout\*).

Potentially billions if global food supply collapses.

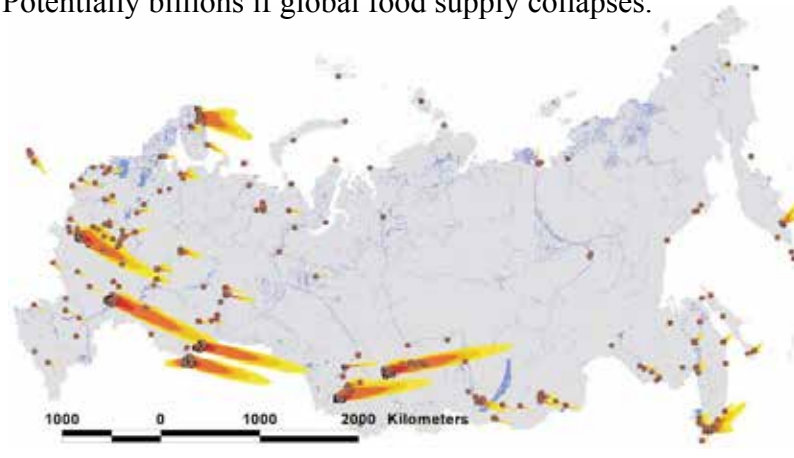

\* Major U.S. attack on Russian nuclear forces (*The U.S. Nuclear War Plan: Time for a Change* <https://www.nrdc.org/sites/default/files/us-nuclear-war-plan-report.pdf>, 2001) Fig. 4.84. See also <http://www.ellsberg.net/archive/us-nuclear-war-planning-for-a-hundred-holocausts>.

## Plan is to "modernize" (replace) *everything* by ~ 2040

- 400 deployed intercontinental ballistic missiles ~ \$85 billion<sup>1</sup>
- 12 ballistic missile submarines ~\$97 billion<sup>2</sup>
- 100 long-range nuclear bombers ~ \$89 billion<sup>3</sup>
- 1000 long-range nuclear cruise missiles ~\$25 billion<sup>4</sup>
- ~ 4000 life-extended and new warheads ~ \$167 billion<sup>5</sup>
- Nuclear command and control ~ \$90 billion<sup>6</sup>
- Nuclear warhead production infrastructure ~ \$50 billion

**Total: ~ \$600 billion**

**(~\$1 trillion including operational costs over 20 years<sup>7</sup>)**

1. <http://www.bloomberg.com/politics/articles/2016-09-06/new-nuclear-armed-missile-seen-costing-u-s-85-billion-up-36>
2. <http://www.gao.gov/assets/680/676281.pdf>
3. [https://www.washingtonpost.com/news/checkpoint/wp/2016/07/20/how-much-does-the-pentagon-secretive-bomber-really-cost-and-should-you-be-allowed-to-know/?utm\\_term=.348cb2793c63](https://www.washingtonpost.com/news/checkpoint/wp/2016/07/20/how-much-does-the-pentagon-secretive-bomber-really-cost-and-should-you-be-allowed-to-know/?utm_term=.348cb2793c63)
4. <http://www.defensenews.com/story/defense/commentary/2016/05/26/irss-does-not-make-sense-nor-do-its-proposed-numbers/8496298/>
5. [https://msa.energy.gov/sites/default/files/nrsa/inlinelinks/FY17SSMP%20Final\\_031116.pdf](https://msa.energy.gov/sites/default/files/nrsa/inlinelinks/FY17SSMP%20Final_031116.pdf)
6. <http://www.gao.gov/products/GAO-16-23> (for 10-year cost) x2.5
7. <http://nationalinterest.org/blog/the-buzz/the-nuclear-cost-debate-gets-even-uglier-17507>
8. <https://www.whitehouse.gov/the-press-office/2013/06/19/fact-sheet-nuclear-weapons-employment-strategy-united-states>

## Why keep and modernize everything?

***“we can ensure the security of the United States and our allies and partners and maintain a strong and credible strategic deterrent while safely pursuing up to a one-third reduction in deployed strategic nuclear weapons from the level established in the New START Treaty.”***

--2013 Nuclear Weapons Employment Strategy of the United States

But Senate Republicans required modernization of everything in exchange for ratifying the New START Treaty in December 2010 (67 votes required to ratify, only 58 Democrats + independents).\*

\*New START Treaty: Resolution Of Advice And Consent To Ratification, 22 Dec. 2010, <http://www.state.gov/t/avc/rls/153910.htm>; “Senate ratifies new U.S.-Russia nuclear weapons treaty,” *Washington Post*, 22 Dec. 2010.

**DoD's projection of nuclear modernization funding hump.**  
*Military worried about the tradeoffs. Is it all necessary?*

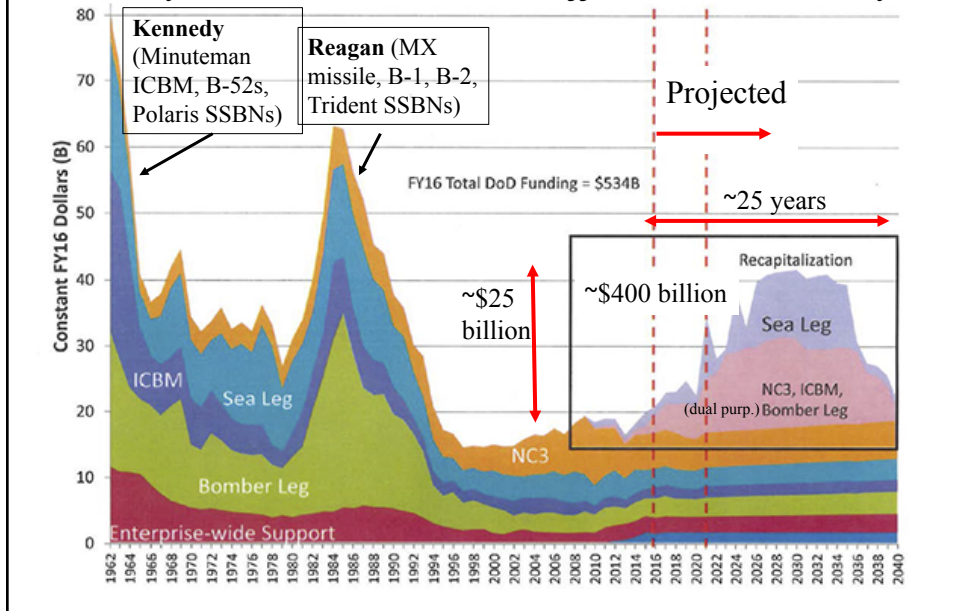

**In addition, NNSA nuclear warhead R&D, life-extension and replacement program for ~ 4,000 warheads\* *Are they all needed?***

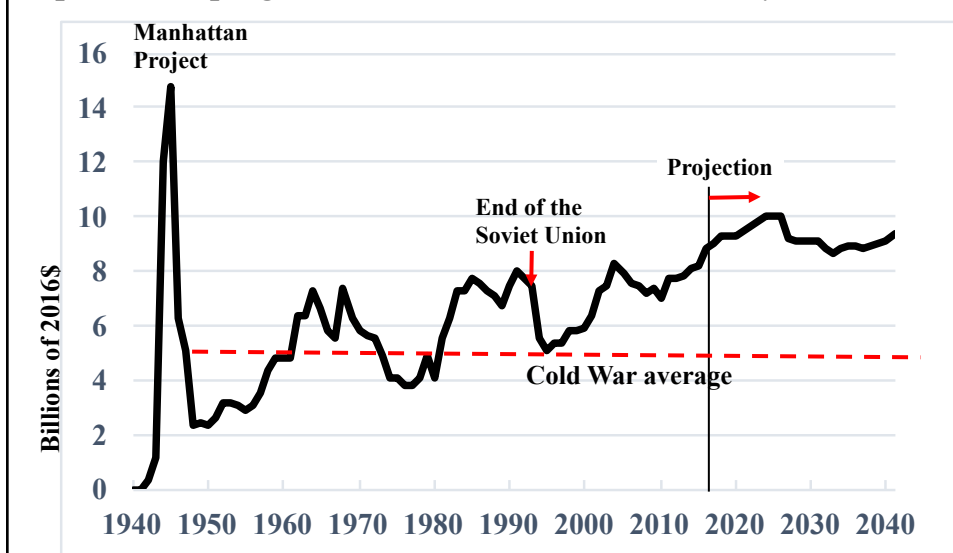

\*Atomic Audit through FY1996; DOE Budget Requests through FY2016; NNSA, Stockpile Stewardship and Management Program, FY2017 projections thereafter.

### New warheads?\*

Projected increase in cost of the warhead program appears to be due to *proposed development of 3 new “interoperable” warheads for U.S. ICBMs and SLBMs instead of life-extending 4 existing warheads.*

New warheads would contain insensitive high explosive (IHE), reducing small risk of a plutonium-dispersal accident. (U.S. warheads already one-point safe with regard to nuclear yield.)

Would contain previously tested components but in new untested combinations. *This could be used as an argument for resuming U.S. nuclear testing, ending the 1996 signed but not yet ratified Comprehensive Nuclear Test Ban, “the longest-sought, hardest fought prize in arms control.”*

Of nine nuclear-weapon states, only North Korea has tested since 1998.

\* Lisbeth Gronlund, *Bad Math on New Nuclear Weapons* (Union of Concerned Scientists, 2015)

### Ballistic Missile Defense

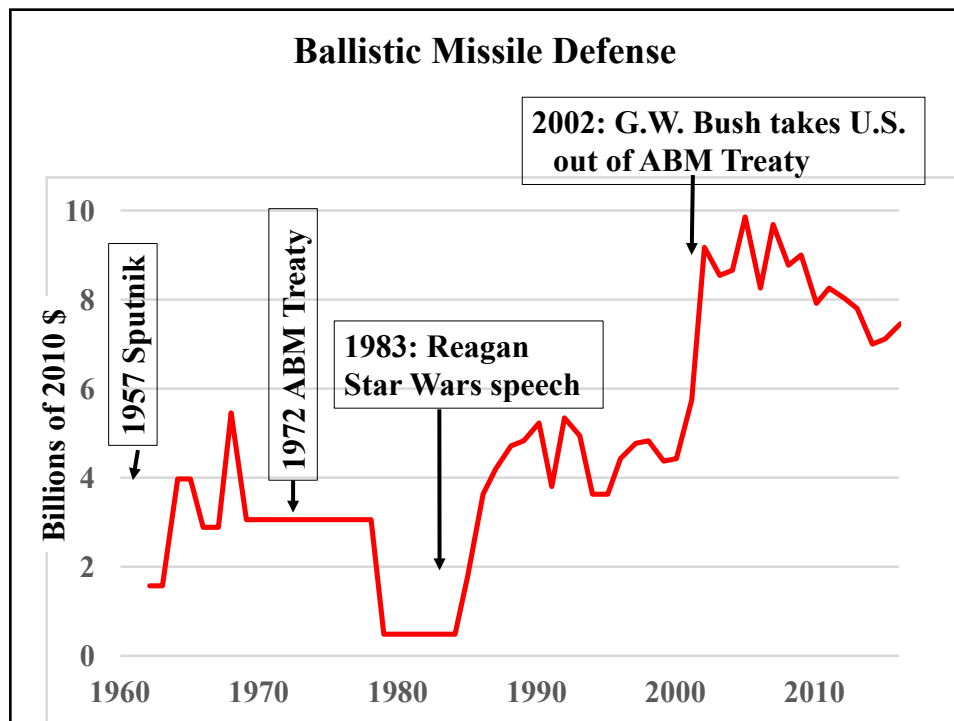



### **Some important proposals for changes**

1. A no-first-use policy.
2. Eliminate launch-on-warning option
3. Eliminate Intercontinental Ballistic Missiles (ICBMs)
4. Limit strategic ballistic missile defense

***No First Use. First use is a desperate threat by a weak state.  
U.S. military spending twice China's, Russia's, Iran's combined.***

Obama wanted no first use but nuclear establishment pushed back,

**2010:** *“there remains a narrow range of contingencies in which U.S. nuclear weapons may still play a role in deterring a conventional or CBW attack against the United States or its allies and partners.”\**

**2013:** *“we cannot adopt such a policy today\*\**

**2016:** *“could unnerve American allies already fearful that America’s nuclear umbrella cannot be relied upon.”*

**U.S. president therefore will continue to have the authority to order first use of U.S. nuclear weapons *without consulting anyone.***

\* DOD, *Nuclear Posture Review Report* (2010).

\*\* DOD, Report on Nuclear Employment Strategy of the United States Specified in Section 491 of 10 U.S.C.

\*\*\* David Sanger and William Broad, “Obama Unlikely to Vow No First Use of Nuclear Weapons,” *New York Times*, 8 September 2016.

## End launch on warning option?

U.S. Strategic Command insists U.S ICBM and half of submarine warheads at sea be kept in a launch-on-warning posture.\*

*Warning time would be 10-30 minutes. There have been no attacks but there have been repeated false warnings of attacks.\*\**

*“We escaped the Cold War without a nuclear holocaust by some combination of skill, luck, and divine intervention, and I suspect the latter in greatest proportion.”*

--General Lee Butler, Commander in Chief, U.S. Strategic Command 1992-1994.

\**Nuclear Posture Review, 2010, p. 27.*

\*\* See e.g. Eric Schlosser, “World War Three, By Mistake,” *New Yorker*, 23 December 2016, <http://www.newyorker.com/news/news-desk/world-war-three-by-mistake>, and a film about a Soviet false alarm in September 1983, <http://themanwhosavedtheworldmovie.com>.

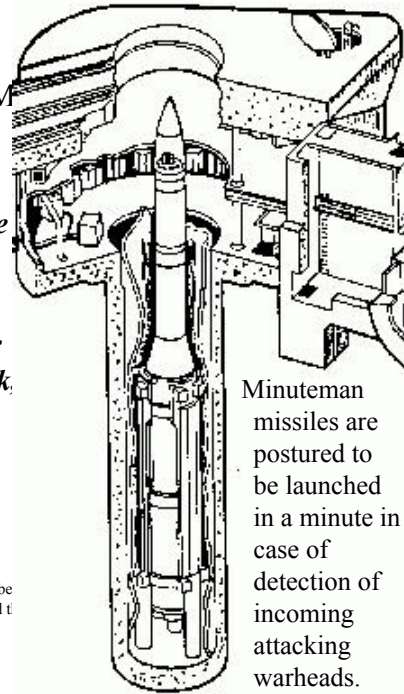

Minuteman missiles are postured to be launched in a minute in case of detection of incoming attacking warheads.

**“Is it time to reduce the Triad to a Dyad, removing the land-based missiles? This would reduce the false alarm danger.”**

--Gen. James Mattis, Trump nominee for Secretary of Defense, 27Jan2015

*8 to 10 U.S. Trident missile submarines are at sea at any time with ~100 warheads each. France, Russia and the UK keep only ~1 submarine at sea. No expectation that a significant fraction of U.S. ballistic submarines could be detected in the foreseeable future.*

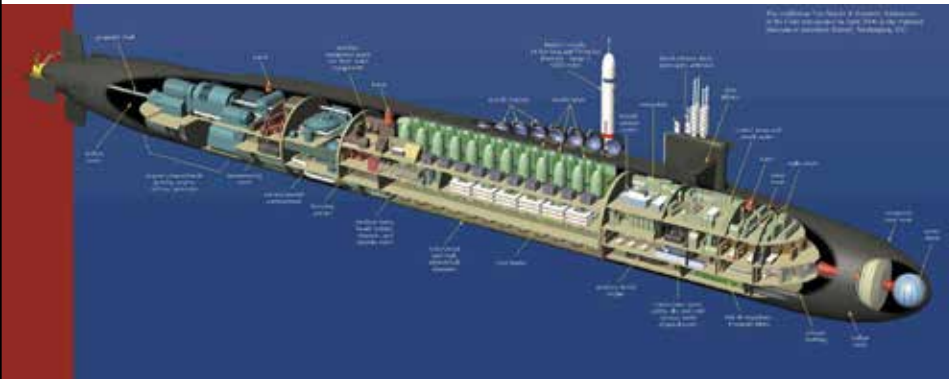

**The third leg: B-52 (1952-62) with up to 20 nuclear cruise missiles each that can be launched from beyond air defenses.**

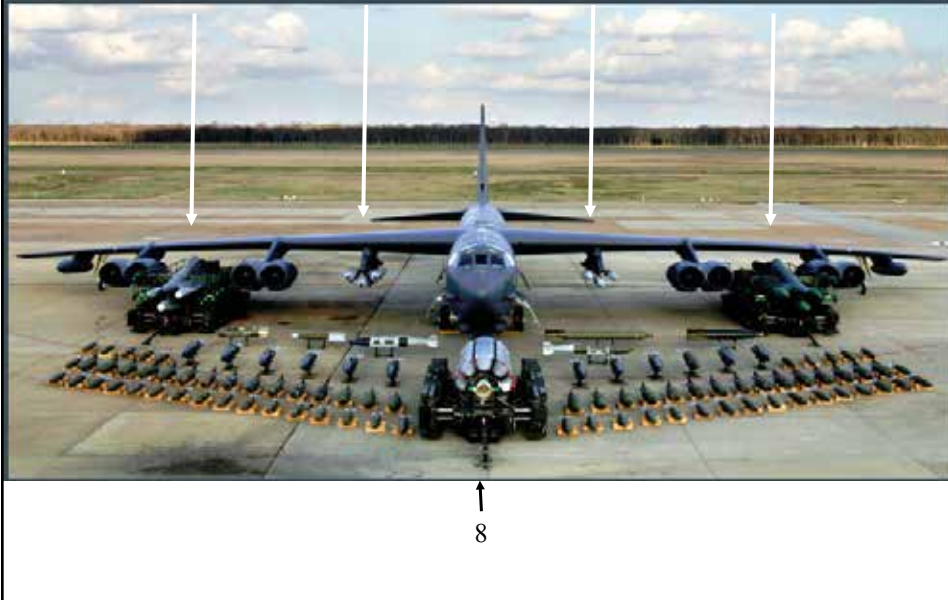

### **U.S. ballistic missile defense efforts: A short history.**

**1957. Sputnik.** U.S. Army and Air Force started design of anti-ballistic missile (ABM) systems with nuclear warheads.

President's Science Advisory Committee advised that technology could be overcome by "*penetration aids*" (radar chaff, decoys, etc.)

**1967.** President Johnson facing presidential candidate Nixon decided to deploy missile interceptors armed with *5-megaton warheads in suburbs* of Boston, Chicago, Detroit, Seattle...causing Not-In-My-Backyard (NIMBY) uprisings.

**1968. Physicists Richard Garwin and Hans Bethe publish article on countermeasures** in *Scientific American* and physicists educate Congress.

**1969:** Nixon moves interceptors away from the cities but too late.

**1972: President Nixon signs ABM Treaty**, limiting each country to a single site with 100 interceptors.

**1974:** U.S. ABM site in North Dakota shut down by Congress.

## History of U.S. BMD (part 2)

**1983.** *“I call upon the scientific community in our country...to give us the means of rendering these nuclear weapons impotent and obsolete.”*

President Reagan had been briefed by Edward Teller on the possibility of *nuclear-explosion-powered X-ray lasers*. Others propose hundreds of orbiting lasers. Critics name program “Star Wars.”

**1984.** **Physicists** (Bethe-Garwin-Gottfried and Kendall) again *explain cost, technical challenges and countermeasures*.

**1987.** Democratic majority in Senate, blocks U.S. exit from ABM Treaty.

**2002.** *George W. Bush, citing Iran, Iraq and DPRK threats, takes U.S. out of BMD Treaty* and deploys ground-based interceptors in Alaska.

**2009.** *Obama shifts emphasis to Aegis interceptors on ships and in Eastern Europe –against Iran and DPRK ballistic missiles.*

***Kinematically, three Aegis ships with 4.5 km/sec interceptors (~ 40 ships planned) could defend U.S. from Chinese & perhaps Russian strategic missiles after U.S. first strike.***

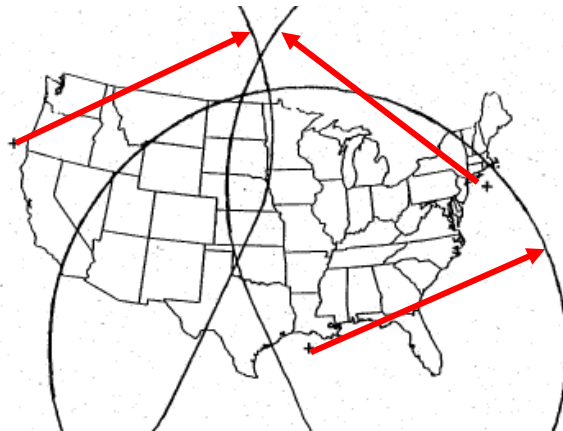

**Russian and Chinese worst-case thinking ignores countermeasures.**

(Image: L. Gronlund, G. Lewis, T. Postol and D. Wright, 1994)

**One possible *countermeasure* to modern non-nuclear hit-to-kill interceptors guided by radar & by infrared in the terminal stage: put warheads in aluminized balloons accompanied by empty balloons containing small battery heaters.**

-- Richard Garwin, "Holes in the missile shield," *Scientific American*, Nov. 2004

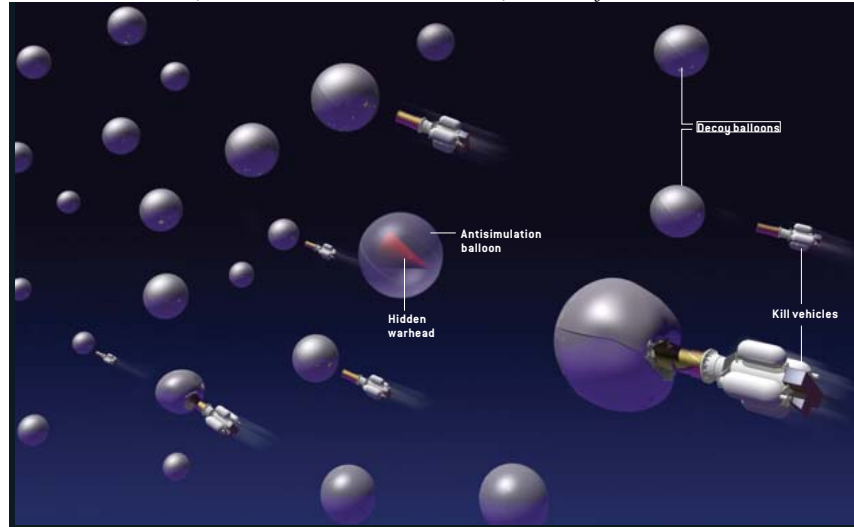

### Chinese and Russian responses

- They worry US BMD might become good enough to stop a weak retaliatory strike after a U.S. first strike.
- Russia refuses further bilateral reductions, and China refuses to even talk about limiting its slow nuclear buildup; and
- Russia maintains a launch-on-warning option while China is moving in that direction, increasing the risk of accidental launch.

#### Why don't Russia and China believe in their countermeasures?

U.S. added countermeasures to its missiles when the Soviet Union deployed 100 missile interceptors to defend Moscow.

"Just in case," however, U.S. also added about 100 nuclear warheads to its attack on Moscow.

### What can physicists (and physics students) do?

- *If you care about an issue, educate yourself and then educate your Representatives and Senators.*
- *If you know of a local NGO working on one of these issues, volunteer to brief them and then go along with them as their expert when they brief your Representatives and Senators.*

**Physicists participated in three uprisings on nuclear-weapons issues so far:**

1. **Anti-radioactive fallout movement** (1954-1962). Resulted in 1963 Partial Nuclear Test Ban Treaty (everywhere but underground).
2. **Anti-ABM movement** (1968-1972). Resulted in the ABM Treaty.
3. **Nuclear-weapons “freeze” movement** (1980-83). Resulted in the first nuclear reduction treaties: Intermediate-range Nuclear Forces and Strategic Arms Reduction Treaties.

### Nuclear-weapon “freeze” movement (1980-83)

Got Congress interested in nuclear arms control again.

Convinced Gorbachev negotiations might be possible; U.S. was not controlled by a military-industrial complex.

Changed Reagan’s focus from nuclear buildup to nuclear disarmament (and “Star Wars”).

One million demonstrating for Nuclear Weapons Freeze in New York City, 12 June 1982 (including Barak Obama)



### Summary

1. We need not replace and modernize the entire nuclear Doomsday Machine.
2. Nuclear first use and launch-on-warning are dangerous options that should be changed.
3. Even though exo-atmospheric ballistic missile defense can be counter-measured, it is blocking progress on nuclear reductions.
4. A new cycle of citizen activism will provide an opportunity for physicists to educate the country on these issues (after educating themselves).